

CONTENTS

Parts		Paragraph
I	<u>GENERAL</u>	1-2
II	<u>INTERPRETATION</u>	3
III	<u>CONDUCT OF LAND BOUNDARY SURVEYS</u>	4-40
	<u>(A) Field notes</u>	4-8
	<u>(B) Origin of co-ordinates & bearings</u>	9-12
	<u>(C) Bearings, distances and co-ordinates</u>	13-16
	<u>(D) Survey instruments</u>	17-19
	<u>(E) Traverses</u>	20-27
	<u>(F) Boundary marking</u>	28-33
	<u>(G) Permanent survey marks</u>	34-35
	<u>(H) Physical features</u>	36-38
	<u>(I) Survey Report</u>	39-40
IV	<u>MEASUREMENTS AND SURVEY TOLERANCES</u>	41-42
V	<u>LAND BOUNDARY PLANS</u>	43-44
VI	<u>SURVEY RECORD PLANS</u>	45-46
VII	<u>DESIGNATIONS OF SUBDIVIDED LOTS</u>	47-56
APPENDIX A	<u>SPECIFICATIONS FOR SURVEY MARKS</u>	
APPENDIX B	<u>DRAUGHTING SPECIFICATIONS FOR SURVEY RECORD PLANS</u>	
APPENDIX C	SPECIMEN LAND BOUNDARY PLAN	
APPENDIX D	SPECIMEN SURVEY RECORD PLAN	
APPENDIX E	<u>A SUMMARY OF THE AMENDMENTS MADE SINCE THE PUBLICATION OF THE FIRST EDITION</u>	

I GENERAL

1. These regulations state the requirements for carrying out all land boundary surveys in Hong Kong under the Land Survey Ordinance (LSO).
2. For the purpose of control of land boundary surveys, every Authorized Land Surveyor (ALS) shall carry out land boundary surveys in compliance with the Land Survey Ordinance and these regulations.

II INTERPRETATION

3. The following are the definitions of the terms used in these regulations:-

"adopted" data means the traverse or land boundary information accepted from previous survey.

"boundary mark" means a survey mark which demarcates a parcel of land.

"boundary stone" means a boundary mark made from white granite, or concrete slab established by the Survey and Mapping Office of Lands Department to demarcate a parcel of land.

"calibration" means the process of checking of a distance measuring equipment against a standard baseline established by the Survey and Mapping Office of Lands Department for corrections to be made to measured lines.

"control survey station" means a survey station emplaced and mathematically fixed under the Hong Kong Control Survey System.

"grid lines" means lines drawn on a map or plan in the form of rectangular grid under the Hong Kong Control Survey System.

"Hong Kong Control Survey System" means the current network of survey stations, emplaced and mathematically fixed, based on the "Hong Kong 1980 Geodetic Datum (HK80)" by the Survey and Mapping Office of Lands Department.

"Hong Kong 1980 Geodetic Datum (HK80)" means the survey datum used by the Survey and Mapping Office, Lands Department since 1980.

"party wall" means a wall wherein the common boundary of two land parcels is located.

"permanent survey mark" means a survey mark established by a land boundary survey for future use and reference.

"picket box" means a control survey station enclosed by a cast iron box.

"survey mark" means a mark defining a surveyed position.

"survey station" means a survey mark over which survey observations are made.

"traverse" means a series of lines between survey stations established by angular and linear measurements starting and closing onto control or old traverse survey stations.

"urban survey mark" means a control survey station made of metal in a mushroom like shape.

III CONDUCT OF LAND BOUNDARY SURVEYS

In order to maintain a uniform standard practice for all land boundary surveys, Authorized Land Surveyors are required to adhere to the following regulations:-

(A) Fields notes

4. The first page of the field notes of every survey shall bear the certificate signed by the Authorized Land Surveyors in the following form:

I , , an Authorized Land Surveyor registered under the Land Survey Ordinance (Cap. 473), hereby certify that these field notes, consisting of pages, are a correct and complete record of the observations and measurements made in the field, either by me, or under my immediate direction and supervision.

I also certify that the land boundary survey, of which the field notes form a part, was carried out in conformity with the Code of Practice approved by the Land Survey Authority under the above Ordinance, and that the survey was completed on theday of, 19.....

Dated thisday of.....19.....

.....
Authorized Land Surveyor

5. An Authorized Land Surveyor or his assistants who carry out the land boundary surveys shall initial and date each page of the field notes. Where an assistant is carrying out the survey under the direction of an authorized land surveyor the latter or his delegate will additionally initial and date those pages of the field notes where the survey has been tested or otherwise checked by him and/or, other field instruction has been given.
6. Field notes shall be prepared for all land boundary surveys performed under the Ordinance and should be a complete original record of all field observations and field measurements recorded in the field. Printout from electronic data recorder shall bear the signature of the surveyor and shall contain equivalent information as contained in traditional field notes. Hand-written field notes shall be neatly and clearly recorded or annotated in permanent blue or black ink and shall not be obliterated, inked over or erased. Corrections may only be made by crossing out the erroneous entry in such a way that it remains legible, and writing the correct value above or alongside it.
7. Field notes shall record the type and identification number of the instruments including theodolite, electronic distance meter (EDM) and steel tape etc. used for the survey. The first page shall show the designation of the land parcel, locality or such other reference or legal descriptions. The date of starting and completing the survey shall also be recorded.
8. All field notes and computations shall be properly kept for submission upon request by the Land Survey Authority.

(B) Origin of co-ordinates & bearings

9. The origin of co-ordinates and bearings shall be obtained from :-
(a) The Hong Kong Control Survey System, or
(b) Any other survey which the Land Survey Authority accepts as suitable for the purposes of land boundary survey.
10. The reliability of any two survey stations used for an origin of bearings shall be proved by testing their agreement with at least one other survey station.
11. Any one of the survey station proven reliable as in paragraph 10 above shall be acceptable as an origin of co-ordinates.
12. The survey tolerances stated in part IV shall be used when proving origins and obtaining agreements with old survey work in the field.

(C) Bearings, distances and co-ordinates

- 13.** Bearings shall be measured with a theodolite reading to 20 seconds or better precision. Traverse bearings shall be made with a minimum of one arc on both face left and face right of the theodolite.
- 14.** Bearings shall be recorded in the field notes in accordance with the precision of the theodolite being used and shown on survey record plan and land boundary plan to the nearest 10 seconds. To facilitate the use of computer in computation and plan production, bearings may be shown on land boundary plan and survey record plan to the nearest 1 second without rounding off the figures.
- 15.** Distances shall be shown in metres and decimals of a metre and read and booked in the field to 0.001 of a metre. Distance measurements shall be made with a steel tape or an electronic distance meter (EDM). All necessary corrections shall be applied.
- 16.** Distances and co-ordinates shall be shown on survey record plans to 0.001 of a metre but shall be shown on the land boundary plan to the nearest 0.01 of a metre. To facilitate the use of computer in computation and plan production, distances and coordinates may also be shown on land boundary plan to the nearest 0.001 of a metre without rounding off the figures.

(D) Survey instruments

- 17.** Distance measuring instruments include steel tape and electronic distance meter (EDM). Steel tape shall be checked against an adopted baseline, which is established by the Land Survey Authority, at intervals not exceeding 6 months, or immediately following repair. EDM instruments shall also be checked against an adopted baseline established by the Land Survey Authority annually or immediately following servicing.
- 18.** A full report of each calibration shall be kept by the Authorized Land Surveyor for record purposes, and shall be presented for inspection when required by the Land Survey Authority.
- 19.** The Land Survey Authority may also inspect instruments used for a land boundary survey to ascertain they are in an operating condition to the satisfaction of the Land Survey Authority.

(E) Traverses

- 20.** Traverses shall start from and close onto control survey stations of the Hong Kong Control Survey System or traverse survey stations established in previously land boundary surveys as shown on deposited survey record plans. Before any traverse begins, the reliability of any two survey stations used for an origin should be proved by the Authorized Land Surveyor testing their agreement with at least a third survey station.
- 21.** No unclosed traverses are allowed.
- 22.** Control survey stations emplaced and mathematically fixed by the Survey and Mapping Office of Lands Department are normally in the form of concrete pillars, picket boxes and urban survey marks, and they are collectively described as control survey stations.
- 23.** Traverse survey stations shall be marked by one of the following survey marks, details for which are specified at [Appendix A:-](#)
 - (a) Iron tubes;
 - (b) Lead plugs;
 - (c) Iron spikes;
 - (d) Survey nails;
 - (e) Wooden pegs; or
 - (f) Cut marks. (cut marks shall only be used where other marks cannot be emplaced)

24. Angular misclosure for a traverse shall not exceed $(30\sqrt{n})$ seconds where n is the number of survey stations in the traverse.
25. Linear misclosure for a traverse shall not exceed $(10 + 2S/15)$ millimetres where S is the total length of the traverse in metres.
26. When a traverse longer than 1.5 km. is run, control bearings shall be observed reciprocally between traverse survey stations and some other control survey stations, at such station intervals as will adequately control the orientation of the traverse lines. The number of traverse survey stations between control bearings shall not be more than fifteen. In special situations and where there is no practical alternative, the Land Survey Authority may approve the use of a single ray, observed to a distant control survey station, to control the orientation of the traverse lines.
27. Traverse misclosures shall be mathematically adjusted.

(F) Boundary marking

28. Boundaries shall be marked at every corner, and where necessary at points on the boundary line if the corners are not intervisible.
29. Where a boundary mark cannot be placed because of an obstruction the boundary mark position shall be offset for establishing its position in future.
30. Boundary marks shall be one of the following survey marks, details for which are specified at [Appendix A](#):-
- (a) Iron tubes;
 - (b) Lead plugs;
 - (c) Iron spikes;
 - (d) Survey nails;
 - (e) Wooden pegs; or
 - (f) Cut marks. (cut marks shall only be used where other marks cannot be emplaced)
31. Every boundary mark shall be placed by bearing and distance from a survey station and checked independently by radiation from another survey station. Where double radiation is impracticable other checking method will be used to verify the accuracies intended. The same requirements apply when fixing the position of old marks, occupation and other elements essential to land boundary definitions.
32. The setting out distance from a survey station to a boundary mark using steel tape and EDM shall not exceed 20 metres and 150 metres respectively. They must be checked independently and recorded accordingly.
33. Curved boundaries shall be marked at both end points and at least one other point on the curve. In addition, curves shall be marked at intervals not exceeding 15 metres, measured along the chord.

(G) Permanent survey marks

34. At least two permanent survey marks (PSMs) shall be established for every land boundary survey in accordance with specifications at [Appendix A](#). Where there are existing PSMs from previous land boundary surveys in the vicinity, they may be accepted as PSMs after verification. No boundary mark shall be at a greater distance than 100 metres from a PSM.
35. All PSMs shall be fixed by double radiation. They shall be described with sketches in the field notes and shown on the survey record plan as to the type of survey mark and its position and height above ground level.

(H) Physical features

36. The positions of all buildings or prominent physical features, on or within 0.5 metre of a boundary line, shall be surveyed, calculated and shown as offsets on the survey record plan. Physical features beyond this and up to 3 metres need only be shown graphically.
37. Boundary on party wall shall have the offset distances in relation to the party wall shown on the survey record plan.

38. Where a boundary is located in a party wall, or between abutting walls, checks must be carried out to confirm that the line of the party wall or the line between abutting wall is a straight line.

(I) Survey Report

39. The Authorized Land Surveyor shall submit a survey report giving the rationale of how the boundaries are established for every land boundary survey. The report should contain information regarding the evidence found and include a copy of any Land Boundary Plan, Survey Record Plan, Identification Plan, Control Traverse and any other plan, sketch, photograph or document containing information or data, which have been used or based on for traverse origin and/or boundary definition or redefinition.

40. Evidence as referred to in paragraph 39 above may include relevant information obtainable from records (such as Demarcation District (DD) sheets, DD Control sheets, DD Enlargement, House Lot Plans, House Lot Plans Retrace, "A" sheet, Cadastral Survey Plans, DD Lot Identification Plan (I plan), Permanent Land Record Plan, Survey Record Plans (SRP), SRP equivalent data, Land Boundary Plans, Aerial photographs, Survey Sheets from Microfilm), as well as ground occupation and investigation, interviews and any other form of data that will support the position and dimensions of the lot under survey.

IV MEASUREMENTS AND SURVEY TOLERANCES

41. If a bearing, a distance or an area is remeasured or re-calculated for verification, re-establishment or whatever reasons, discrepancies are acceptable if they are within the listed tolerances below. The original values will then be adopted. If the discrepancies fall outside these tolerances the new values must be conclusively checked for correctness. If confirmed, the original values must be considered as superseded by the new values with reasons clearly recorded. The tolerances are:

(1) Survey tolerances - **Bearing** measurements:

<u>Distance</u>	<u>Tolerance</u>
under 15 m	(+/-) 2' 00"
15 m - 150 m	(+/-) 1' 00"
Over 150 m	(+/-) 0' 30"

(2) Survey tolerances - **Distance** measurements:

Tolerance:

**(+/-) (0.015 + 0.0001 x distance in metres)
metre**

(3) Survey tolerances - **Area** calculations:

Tolerance: **(+/-) 0.1 %**

42. Areas shall be **rounded off** to the nearest unit as follows:

<u>Area of Lot</u>	<u>Expressed in</u>	<u>Rounded off to nearest</u>
Under 2000 m²	m²	0.1 m²
2000 m² and above	m²	1 m²

However, areas already committed may be exempted from this rule, in which case the tolerance in paragraph 41(3) will apply.

All areas shown on plans shall be qualified with the word "about".

V LAND BOUNDARY PLANS

43. For the purpose of this Ordinance, a land boundary plan shall be prepared for division of land for attachment to the instrument for registration with Land Registry under the Land Registration Ordinance (Cap. 128). In addition, duplicate copy of the land boundary plan and survey record plan shall also be deposited with the Land Survey Authority.

44. The land boundary plan shall satisfy the following requirements:

1. Land parcel information:

- a. A plot of boundaries drawn to scale;
- b. Designation of the subject lot or parcel;
- c. The area of each lot or parcel;
- d. Notation and if applicable, the description of each boundary corner;
- e. Boundary dimensions of subject lot or parcel; and
- f. Abutting land information.

2. Supporting information:

- a. Grid lines with co-ordinates;
- b. Location diagram of the site, where necessary;
- c. The plot, with details of colouring and abbreviations;
- d. Scale;
- e. Standard north point symbol; and
- f. Co-ordinates of each boundary corner may be shown at the discretion of the Authorized Land Surveyor.

3. Plan size:

Any such plan and copy thereof shall be of A3 size or of such size as specified under the Section 8 of Land Registration Regulations (Cap. 128).

4. Plan numbering:

Plan numbering shall be a similar counterpart to that of the corresponding survey record plan.
Example:-

LBP/HK/001/0001/D1
LBP = Land Boundary Plan
HK = Hong Kong (District Survey Office)
001 = Registration number of ALS
0001 = Plan number as prepared by the ALS
D1 = Dimension Plan (D1, D2, ..., Dn etc.) or
S1 = Setting out plan (S1, S2, ..., Dn etc.)

Note: DSO Hong Kong and Kowloon shall be abbreviated to HK and KL respectively without any need to specify further whether it is east, west or central. For other DSOs, their abbreviations are shown in the brackets: Kwai Tsing(KT), Island (IS), North (DN), Sai Kung (SK), Shatin (ST), Tai Po (TP), Tsuen Wan (TW), Tuen Mun (TM) and Yuen Long (YL).

5. Every land boundary plan shall be signed and certified by the Authorized Land Surveyor and bear a certificate in the following form:

I , , an Authorized Land Surveyor registered under the Land Survey Ordinance (Cap. 473), hereby certify that this land boundary plan has been prepared from land boundary surveys that were carried out by me, or under my direct supervision, in conformity with the Code of Practice approved by the Land Survey Authority under the above Ordinance, and that this plan correctly represents that survey completed on the day of 19

Dated this day of 19.....

.....
Authorized Land Surveyor

VI SURVEY RECORD PLANS

45. The survey record plan (SRP) is a plan which records survey data (including land boundaries, survey evidence, survey marks, traverses, alignments and significant ties to occupation and related features) used in a land boundary survey. The objectives of preparing a SRP are:

1. to maintain repeatability such that:
 - a. the SRP alone is able to ensure users to be able to maintain consistency of boundary definition,
 - b. the SRP alone can allow a checker to satisfy that consistency has been achieved, and
 - c. positive identification of marks and boundary features are made possible; and
2. to comprehensively convey **what** constitutes and marks the boundary. The SRP alone cannot reveal **why** a boundary is so defined or **how** decision has been made.

46. The survey record plan shall include the following information:

1. Land parcel information:
 - a. A to-scale plot of boundaries;
 - b. Designation of the subject lot or parcel;
 - c. The area of each lot or parcel;
 - d. Notation and if applicable, description of each boundary corner;
 - e. Boundary dimensions of subject lot or parcel;
 - f. Co-ordinates of each boundary corner; and
 - g. Abutting land information.
2. Survey station information:
 - a. A plot of survey stations;
 - b. Description of the survey stations; and
 - c. Bearings and distances of traverses.
3. Supporting information:
 - a. Grid lines with co-ordinates;
 - b. Location diagram, inset diagram;
 - c. Co-ordinates of points;
 - d. Scale;
 - e. Reference to relevant document and computations where necessary;
 - f. Standard north point symbol;
 - g. Setting out and PSM radiations if applicable (checking radiations are not required to be shown); and
 - h. Positions and descriptions of PSMs.

4. Plan numbering:

Plan numbering shall be numbered as follows:-

e.g. SRP/HK/001/0001/D1(R)

SRP = Survey Record Plan

HK = Hong Kong (District Survey Office)

001 = Registration number of ALS

0001 = Plan number as prepared by the ALS

D1 = Dimension Plan (D1, D2,...,Dn etc.) or

S1 = Setting out plan (S1, S2,...,Dn etc.)

(R) = The corresponding land boundary plan have been registered with Land Registry.

Note: DSO Hong Kong and Kowloon shall be abbreviated to HK and KL respectively without any need to specify further whether it is east, west or central. For other DSOs, their abbreviations are shown in the brackets: Kwai Tsing(KT), Island (IS), North (DN), Sai Kung (SK), Shatin (ST), Tai Po (TP), Tsuen Wan (TW), Tuen Mun (TM) and Yuen Long (YL).

5. Every survey record plan shall be signed and certified by the Authorized Land Surveyor and bear a certificate in the following form:

I , , an Authorized Land Surveyor registered under the Land Survey Ordinance (Cap. 473), hereby certify that this survey record plan has been prepared from land boundary surveys that were carried out by me, or under my direct supervision, in conformity with the Code of Practice approved by the Land Survey Authority under the above Ordinance, and that this plan correctly represents that survey completed on the day of 19

Dated this day of 19

.....
Authorized Land Surveyor

VII DESIGNATIONS OF SUBDIVIDED LOTS

47. For the purpose of this Ordinance, the resultant parcels of land when a lot is subdivided shall be designated in accordance with the following practice. It is essential that a standardized system of designations and abbreviations is adopted so that the subdivided lots can be unambiguously and easily identified.
48. When a lot is subdivided for the first time, the subdivided portions are called "Sections" which shall be designated with letters in alphabetical order successively as Section A, Section B, Section C etc. except for the last section which shall be designated as the Remaining Portion of the original lot (see Example 1). There shall be no skipping in the sequence of the letters (the letters I and O shall also be used). If Z is reached then the sequence shall be continued by prefixing A to the letter, then B, and so on, e.g. Section Z, Section AA, Section AB etc.

Example 1: First Subdivision of Lot 123

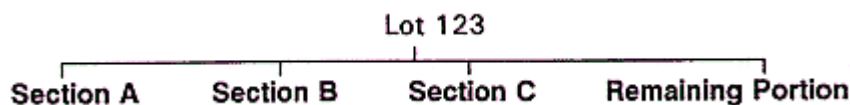

49. In a subsequent subdivision of a section, the subdivided portions are called "Subsections" which shall be designated with numbers successively as Subsection 1, Subsection 2, Subsection 3 etc. except for the last subsection which shall be designated as the Remaining Portion of the original section (see Example 2).

Example 2: Subdivision of Section A of Lot 123

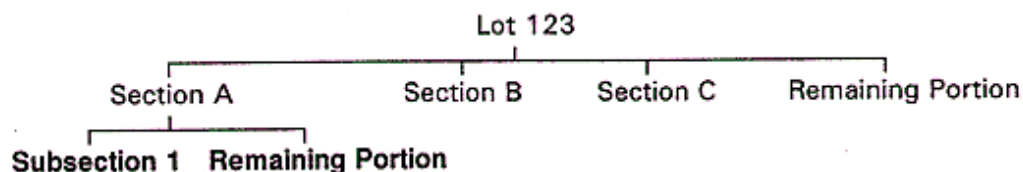

50. On further subdivisions of a section or a subsection into the next tiers, the key to the designations is that a section is followed by a subsection which in turn followed by a section, ad infinitum. The last portions shall always be designated as the Remaining Portion of the original section/subsection. Sections are labelled by using letters and subsections are labelled by using numbers (see Example 3).

Example 3: Subdivision of Subsection 1 of Section A of Lot 123

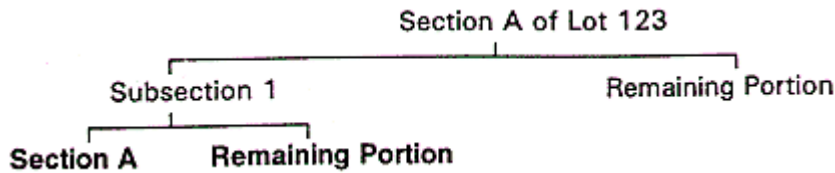

51. If the Remaining Portion of a lot, a section or a subsection is further subdivided, the subdivided portions become additional sections or subsections of the original lot/section/subsection. For new sections, they shall be labelled alphabetically with the letter sequence following on from the letters used in the previous subdivision (see Example 4). For new subsections, they shall be labelled by numbers following on from the sequence in the previous subdivision (see Example 5). There shall be no skipping in the sequence of the letters or numbers. The last section or subsection shall be designated as the Remaining Portion of the original lot/section/subsection.

Example 4 : Subdivision of the Remaining Portion of Lot 123

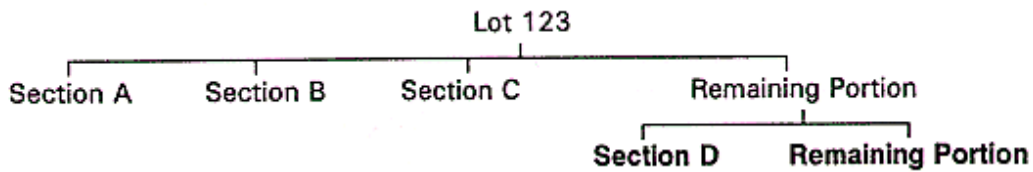

Example 5 : Subdivision of the Remaining Portion of Section A of Lot 123

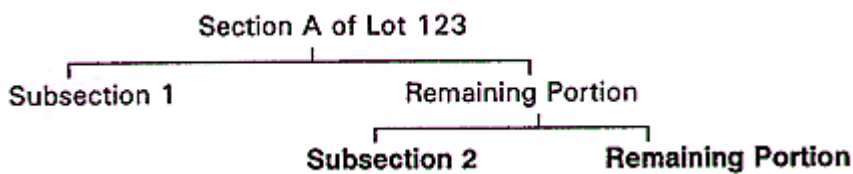

52. When a portion of a lot/section/subsection is resumed by the Government, it will not be given any designation. The land parcel with non-designated portion(s) being resumed will become known as the Remaining Portion of the original lot/section/subsection. On subdivision of a remaining portion involving resumed portion(s) with no designation(s), labels for the designations of the subdivided portions shall start with the letter "A" for sections or the number "1" for subsections if the parent lot/section/subsection has not been subdivided before, the new sections/subsections shall be labelled by letters or numbers following on from the letter or number sequence of the designated sections/subsections in the previous subdivision (see Examples 8 and 9).

Example 6: Subdivision of the Remaining Portion of Lot 123 involving resumed portion(s) (Lot 123 has not been subdivided previously).

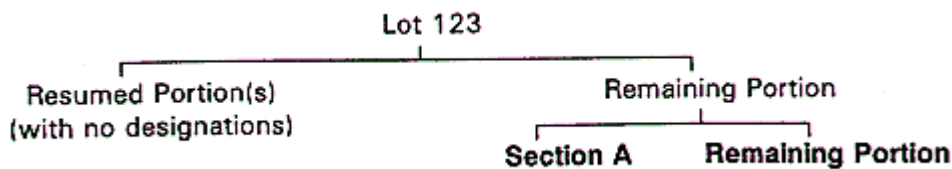

Example 7: Subdivision of the Remaining Portion of Section A of Lot 123 involving resumed portion(s) (Section A of Lot 123 has not been subdivided previously).

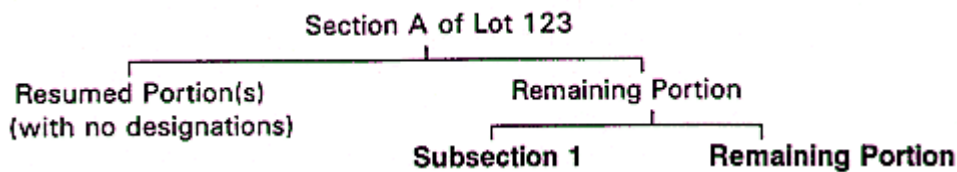

Example 8: Subdivision of the Remaining Portion of Lot 123 involving resumed portion(s) with no designation(s) (Lot 123 has been subdivided previously).

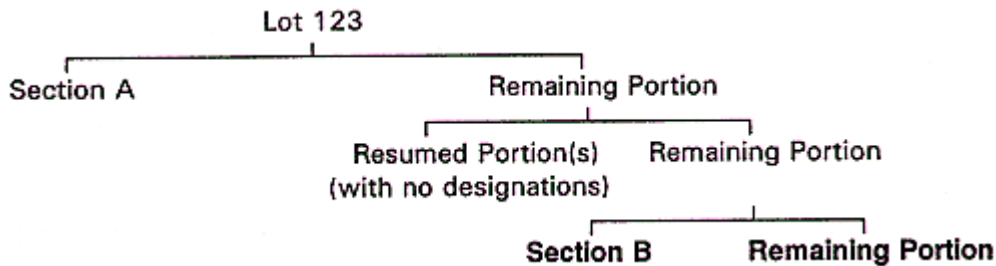

Example 9: Subdivision of the Remaining Portion of Section A of Lot 123 involving resumed portion(s) (Section A of Lot 123 has been subdivided previously).

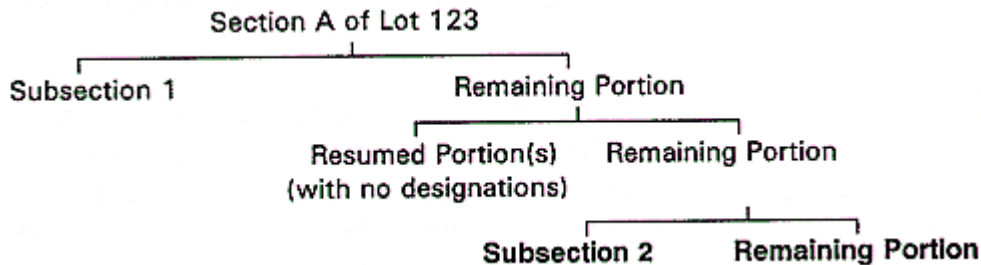

53. Sections/subsections of a lot created in previous subdivisions may sometimes be amalgamated to form a new parcel of land. The resultant land parcel shall be assigned with new designation except when all the subdivided portions of a lot/section/subsection are involved in the amalgamation, in which case, the original lot/section/subsection will deem to have been "re-established" by means of amalgamation and the original designation shall be adopted. On further subdivision of the re-established lot/section/subsection, the new sections/subsections shall be designated in the manner as described in paragraph 51 above to avoid confusing them with the old sections/subsections which existed prior to amalgamation (see Examples 10 and 11).

Example 10: Amalgamation involving all subdivided portions of Lot 123

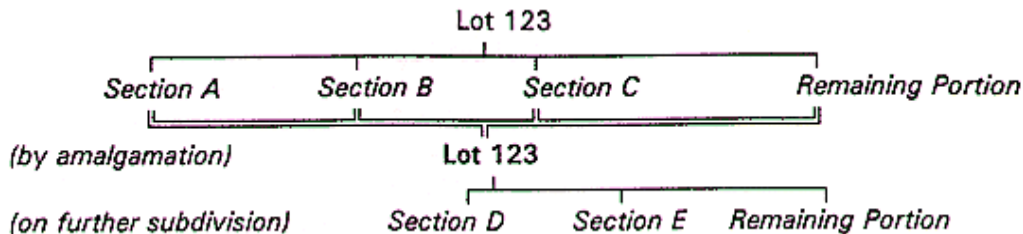

Example 11: Amalgamation involving all subdivided portions of Section A of Lot 123

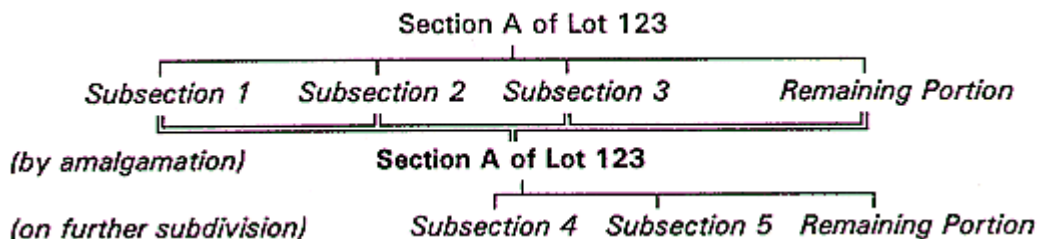

54. When the amalgamation involves only some of the subdivided portions of a lot/section/subsection, the resultant land parcel will be regarded as a new section or subsection of the original lot/section/subsection depending on the highest level of the subdivided portions in the subdivision tree involved. It will be a section if the highest level of subdivided portions in the amalgamation involves section. It will be a subsection if the highest level of subdivided portions in the amalgamation involves subsections. The resultant land parcel shall be designated as the Remaining Portion of the original lot/section/subsection if the highest level of the subdivided portions in the amalgamation involves the remaining Portion of that lot/section/subsection. On further subdivision of the resultant land parcel, the new sections shall be designated in the manner as described in paragraph 51 above (see Examples 12 and 13).

Example 12: Amalgamation involving some of the subdivided portions of Lot 123 (including the Remaining Portion of Lot 123).

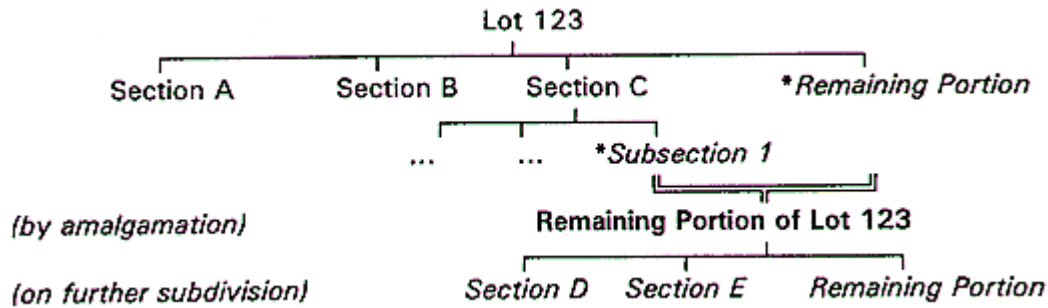

*** subdivided portions involved in the amalgamation**

Example 13: Amalgamation involving some of the subdivided portions of Lot 123 (including the Remaining Portion of Section A of Lot 123).

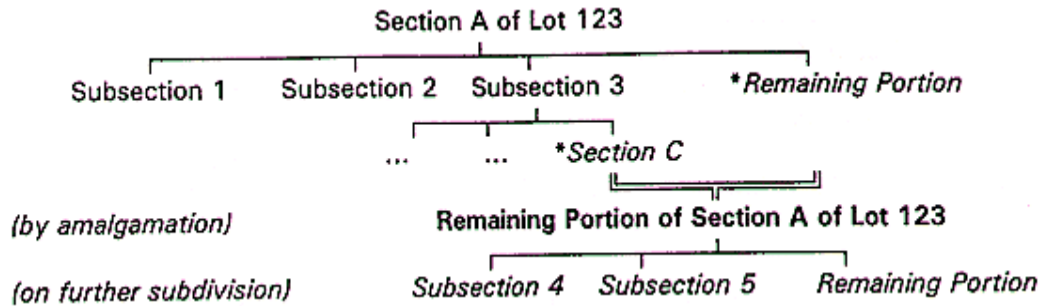

*** subdivided portions involved in the amalgamation**

55. If the Remaining Portion of the original lot/section/subsection is not involved in the highest level of the subdivided portions in the amalgamation, the resultant land parcel shall be designated by a letter (for section) or a number (for subsection) following on from the last letter or number used in the previous subdivision at that highest level. On further subdivision of the resultant land parcel, the new sections/subsections shall be designated in the manner as described in paragraphs 49 and 50 (see Examples 14 and 15).

Example 14: Amalgamation involving some of the subdivided portions of Lot 123 (excluding the Remaining Portion of Lot 123).

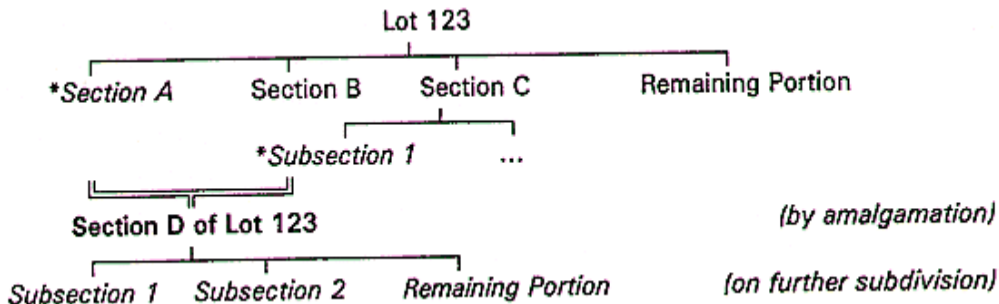

*** subdivided portions involved in the amalgamation**

Example 15: Amalgamation involving some of the subdivided portions of Section A of Lot 123 (excluding the Remaining Portion of Section A of Lot 123).

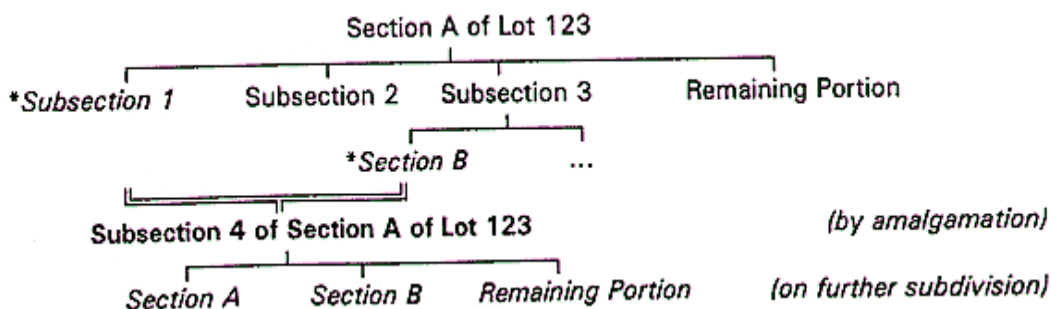

*** subdivided portions involved in the amalgamation**

56. The following abbreviations shall be used for the designations of the subdivided lots shown on survey record plans and land boundary plans.

- | | | |
|-----|-------------------|------|
| (a) | Section | -S. |
| (b) | Subsection | -ss. |
| (c) | Remaining Portion | -RP |

e.g. Lot 123 S.O ss.1 S.I RP - The Remaining Portion of Section I of Subsection 1 of Section O of Lot 123

Appendix A

SPECIFICATIONS FOR SURVEY MARKS

1. **Iron tube** will consist of, a galvanised iron pipe at least 350 mm long, and 20 mm in diameter, driven vertically into the ground.
2. **Lead plug** will consist of a hole drilled or punched into hard surface filled with lead and centred with a tack. The hole should be at least 8 mm in diameter and at least 15 mm deep.
3. **Iron spike** will be at least 100 mm in length and 12 mm in diameter, driven into the ground to finish either flush with the ground surface or beneath it.
4. **Survey nail** will be at least 5 mm in diameter with a minimum length of 50 mm and will have a head of at least 10 mm in diameter.
5. **Wooden peg** will be made from hardwood and can be of two sizes:
 - (a) 25 mm square and 150 mm long, or
 - (b) 70 mm square and 400 mm long.The position of the boundary corner will be marked on the top of the peg by a small metal tack.
6. **Cut mark** will consist of a hole 5 mm in diameter and at least 10 mm deep, drilled into hard surface. It will be surrounded by a triangle shaped groove with equal sides 100 mm long and at least 2 mm deep.
7. **Permanent survey mark (PSM):** Any of the survey marks 1 to 4 above fixed on a permanent feature may be used as a PSM. Alternatively a well defined physical feature may be used as a permanent survey mark as long as the feature chosen can be positively identified from a simple description or diagram on a survey record plan.

Appendix B

DRAUGHTING SPECIFICATIONS FOR SURVEY RECORD PLAN

1. **Plan form**
 - 1.1 All survey record plans shall be fair drawn in black ink, on the specified survey record plan form in a standard transparent format, size A2 (420 mm x 594 mm). The length of this form may be extended from 594 mm to 700 mm to include a second column for tabulation of bearings and distances where required.
 - 1.2 A survey record plan shall be drawn on one plan form unless a reduction in scale will adversely affect the quality of the plan. Should two or more plan forms be required each sheet shall be boldly labelled 'sheet of sheets' and clear joining lines will be shown between sheets.

2. Scale

- 2.1 All survey record plans shall be produced at a preferred metric scale e.g. 1:2000; 1:1000; 1:500; 1:200; 1:100 or 1:50, that will suitably and clearly illustrate the fully details of the survey. Where necessary intricate and cluttered detail shall be clarified by an enlarged and/or, distorted diagram.

3. Grid (plotting) lines

- 3.1 Plans shall normally be plotted on a grid parallel to the sides of the plan form, north uppermost. However when the orientation of the survey dictates otherwise the grid may be tilted, but never be more than 90 degrees from the normal north pointing.
- 3.2 The position of the grid lines shall be indicated by intersecting cuts at the plan border and at least two meridians and two perpendiculars, suitably spaced, shall be shown. The co-ordinate value of each grid line will be shown.

4. Plan drawing and detail

- 4.1 All survey record plans shall be drawn, either by computer plotter, by hand, or by a combination of both.
- 4.2 The plans shall clearly show all traverses run, information adopted from previous surveys used for the boundary definition. Boundary and traverse lines adopted shall be annotated as such on the face of the plan. If possible traverse bearings and distances shall be shown on the face of the plan but may also be tabulated, with co-ordinates of the radiated points in the margin of the plan.
- 4.3 All survey marks used shall be described on the face of the plan by type and number. In the case of old marks found or adopted, a reference to the adopted survey record plan shall be included, either beside the mark, or if all the old marks originate from the same survey, in the margin. Details of the ground placement of all marks except those placed flush in concrete roads and footpaths and those adopted will be shown. e.g. IS3 (road edge of channel); OIT7 (buried 0.10m)
- 4.4 New traverse survey marks shall be numbered consecutively, commencing from Arabic numeral 1. Boundary marks shall be labelled alphabetically in consecutive order in a clockwise direction from the most northerly north-west corner, if Z is reached then the sequence shall be continued by prefixing A to the alphabet, then B, and so on. e.g. Z, AA, AB, etc. The letters I and O will not be used.
- 4.5 The legal description of the subject lot or parcel and its abutments as well as all relevant road and street names shall be shown on the face of the plan.
- 4.6 Areas of all land parcels will be shown on the face of the plan.
- 4.7 Lines which have been observed but not measured shall be annotated 'obs. only'.
- 4.8 A standard north point, as specified at paragraph 6(1)(h) of this specification, will be shown on all survey record plans.
- 4.9 Survey record plans used for reference shall be shown on the face of the plan.

5. Symbols and abbreviations

- 5.1 The following symbols shall be used to indicate the type of survey mark placed, found or adopted:-

	<u>New/Adopted</u>	<u>Old mark found</u>
(a) Boundary stone	□	■
(b) Control survey station	⊙	⊗
(c) Permanent survey mark	⊗	▲
(d) All other survey marks	○	●

5.2 The following abbreviations shall be used when referring to specific survey marks:-

(a) Boundary stone	- BS
(b) Survey nail	- Nail
(c) Cut mark	- CM
(d) Iron spike	- IS
(e) Iron tube	- IT
(f) Lead plug	- LP
(g) Wooden peg	- Peg
(h) Permanent survey mark	- PSM
(i) Picket box (over any mark)	- PB
(j) Urban survey mark	- USM
(k) Concrete pillar	- CP

Additionally all existing survey marks found, with the exception of boundary stones, will be prefixed with an **O**, for old e.g. **OIT**.

5.3 Other allowable abbreviations are:-

(a) Adopted	- adpt.
(b) Boundary	- bdy.
(c) Building	- bldg.
(d) Calculated	- calc.
(e) Concrete	- conc.
(f) Observed	- obs.

6. Line work and lettering

6.1 Line work on survey record plans shall be standardised as follows:-

<u>Line</u>	<u>Recommended Gauge</u>	<u>Shown</u>
(a) Measured and, or, observed lines; and origin of bearings	0.25 mm	-----
(b) Adopted or calculated lines and grid lines	0.25 mm	—————
(c) Boundary lines, subject lot or parcel	0.7 mm	—————
(d) Boundary lines, other than (c) above, sheet joining lines	0.5 mm	-----
(e) Road/street alignments	0.5 mm	—————

(f) Fences (fence on boundary
annotate only) 0.25 mm



(g) Building or structures
(Describe fully - add approximate
age) 0.25 mm

(see below)

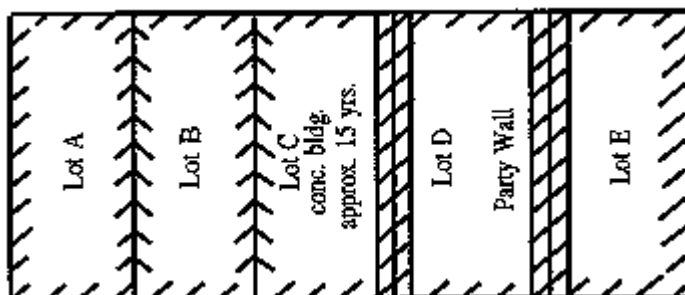

(h) Standard north point symbol 0.5 mm (see below)

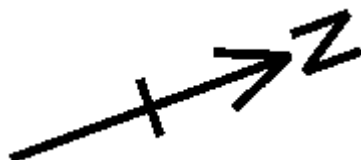

6.2 Specifications for lettering and figure work are:

<u>Item</u>	<u>Recommended Height</u>	<u>Recommended Gauge</u>
(a) Descriptions and areas of subject parcels, road names, plan titles, sheet numbers and sheet joining line labels	7 mm	0.7 mm
(b) Descriptions of abuttals, etc., diagram titles, specific usage names or descriptions, standard data in bottom parcels.	5 mm	0.5 mm
(c) All other lettering and figure work	2.5 mm	0.25 mm

Appendix E

A Summary of the amendments made since the publication of the First Edition

Item	Paragraph/ Page No.	Amendment	Reason for the amendment
1	Para. 4, Page 3; Para. 44(5), Page 11; Para. 46(5), Page 13; Sample Plan, App. C; Sample Plan, App. D	"(28 of 1995)" is replaced by "(Cap. 473)"	The Land Survey Ordinance has been incorporated into the Laws of Hong Kong as Chapter 473.

- | | | | |
|---|---|---|--|
| 2 | Para. 14, Page 5 | The following sentence is added to the end of the paragraph: "To facilitate the use of computer in computation and plan production, bearings may be shown on land boundary plan and survey record plan to the nearest 1 second without rounding off the figures." | This amendment was added after considering the comments received from ALSs on an earlier proposal. It is to accommodate the use of computer in computation and plan preparation which helps improve work efficiency of ALSs. |
| 3 | Para. 16, Page 5 | The following sentence is added to the end of the paragraph: "To facilitate the use of computer in computation and plan production, distances and coordinates may also be shown on land boundary plan to the nearest 0.001 of a metre without rounding off the figures." | This amendment was added after considering the comments received from ALSs on an earlier proposal. It is to accommodate the use of computer in computation and plan preparation which helps improve work efficiency of ALSs. |
| 4 | Para. 44(4), Page 11;
Para.46(4), Page13 | The abbreviation for DSO/ST, "Shatin (ST)," is added | The abbreviation for DSO/Shatin has been inadvertently omitted. |
| 5 | Para. 44(1), Page 10 | The requirement to show co-ordinates of each boundary corner as in (g) is deleted. | Based on comments of some ALSs, coordinates need not be shown on land boundary plan. It was considered a waste of effort as coordinates are already available in the survey record plan. |
| 6 | Para. 44(2), Page 10 | The following is added to the end of the paragraph: "(f) Coordinates of each boundary corner may be shown at the discretion of the Authorized Land Surveyor." | Following the reasons in Item 5 above, the inclusion of the new sub-paragraph is to make the coordinates on land boundary plan optional. |
| 7 | Para. 6.1(a), App.B (Page 3 of 5) | The following is added to the end of the paragraph: "; and origins of bearings" | Origins of bearings should be shown in dashed lines. The lines shown on the sample plan at Appendix D is incorrect. This amendment is to clarify the ambiguity that though the origins of bearings are measured it is also in a sense "adopted". |
| 8 | Sample Plan, App. C | The word "(About)" is added to qualify areas shown on plan | The word "About" which qualifies the surveyed area was inadvertently omitted in the sample plan. |
| 9 | Sample Plan, App. C;
Sample Plan, App.D | "Examined by:" and "Accepted for record by:" in the panel "For Official Use" are deleted | To avoid the misunderstanding that the deposited plans have been examined and approved by the Land Survey Authority |

- | | | | |
|----|--|--|---|
| 10 | Para. 26, Page 6 | The paragraph is rewritten as: "When a traverse longer than 1.5km is run , control bearings shall be observed reciprocally between traverse survey stations and some other control survey stations, at such station intervals as will adequately control the orientation of the traverse lines. The number of traverse survey stations between control bearings shall not be more than fifteen. In special situations and where there is no practical alternative, the Land Survey Authority may approve the use of a single ray, observed to a distant control survey station, to control the orientation of the traverse lines. | Some ALSs found it difficult in some circumstances to comply with the original requirements for reciprocally observed control bearings for long traverses. After reviewing the situation, the Land Survey Authority decided to relax the original requirements. |
| 11 | Para. 5.2, App. B (Page 3 of 5) | The abbreviation "CP" for "concrete pillar" is added | On some survey record plans, control survey stations in the form of concrete pillars are given different abbreviations. This is to standardized the abbreviation. |
| 12 | Part III, section (I) Table of Content & Page 8 | The section is retitled "Survey Report" | This section is retitled so as to put the emphasis on the ALSs' requirement to submit survey report giving the rationale of boundary definition, instead of on how the land boundaries should be determined. |
| 13 | Para. 39, Page 8 | The paragraph is rewritten as "The Authorized Land Surveyor shall submit a report giving the rationale of how the boundaries are established for every land boundary survey. The report should contain information regarding the evidence found and include a copy of any Land Boundary Plan, Survey Record Plan, Identification Plan, Control Traverse and any other plan, sketch, photograph or document containing information or data, which have been used or based on for traverse origin and/or boundary definition or re-definition." | The paragraph is rewritten to accord with the spirit of the Ordinance. there is no provision in the Ordinance to control over the determination of parent lot boundaries in a subdivision. |

14	Para.40, Page 8	<p>The paragraph is rewritten as "Evidence as referred to in paragraph 39 above may include relevant information obtainable from records (such as Demarcation District (DD) sheets, DD Control sheets, DD Enlargement, House Lot plans, House Lot Plans Retrace, "A" sheet, Cadastral Survey Plans, DD Lot Identification Plan (I Plan), Permanent Land Record Plan, Survey Record Plans (SRP), SRP equivalent data, Land Boundary Plans, Aerial photographs, Survey Sheets from Microfilm), as well as ground occupation and investigation, interviews and any other form of data that will support the position and dimensions of the lot under survey."</p>	Same as above.
15	Para. 5.1, App. B (Page 2 of 5)	<p>The symbol for USM is adopted to be used for all types of control survey stations including USM. The symbol originally used for control survey station is deleted.</p>	<p>USM is just one form of control survey stations. It has similar degree of accuracy in the control system and hence should not be singled out by using a separate symbol in the presentation on SRP. The symbol originally used for USM is adopted for control survey stations because it is simpler.</p>
16	Para. 42, Page 9 Para.4.6, App. B (Page 2 of 5)	<p>Areas shown on LBP and SRP shall be qualified with the word "about"</p>	<p>This requirement has been inexplicitly spelt out in the sample plans. The amendments serve to make it explicit.</p>
17	Para. 44(4), Page 11; Para.. 46(4), Page 13	<p>The abbreviation for DSO/KT, "Kwai Tsing (KT)" is added</p>	<p>The abbreviation for DSO/Kwai Tsing has been inadvertently omitted</p>
18	Para. 34, Page 7 Para.7, App. A	<p>The last sentence of Para. 7, "No boundary mark shall be at a greater distance than 100 metres from a PSM", is moved to the end of Para. 34.</p>	<p>Appendix A mainly concerns with the physical specifications of survey marks. It is more appropriate for this requirement to be included in Para. 34.</p>

An entirely new part on "Designations of Subdivided Lots" is added. Some ALSs have encountered problems with the Land Registry regarding the designations of the subdivided lots shown on the land boundary plan. This part is to standardise the practice in assigning designations to sections on subdivision of land. The provisions have been agreed by the Land Registry.

- Notes:**
- (1) The amendments in Items 1 to 9 have taken effect on 29 November 1996 by publishing of Corrigendum No. 1/96 (November) under G.N. 5525 n the Gazette.M.
 - (2) The amendments in Items 10 to 11 were implemented as administrative measures by incorporating them into Land Survey Authority Circular No. 2/97 dated 20 June 1997.
 - (3) The amendments in Items 12 to 15 have been endorsed by the Land Boundary Survey Committee of SMO in its 32nd meeting on 21 November 1997.
 - (4) The amendments in Items 16 to 18 have been endorsed by the Land Boundary Survey Committee of SMO in its 33rd meeting on 16 April 1998.
 - (5) The amendments in Item 20 have been agreed by the relevant Government departments (i.e the Land Registry, the Lands Administration Office and the Legal Advisory and Conveyancing Office of the Lands Department).